

1

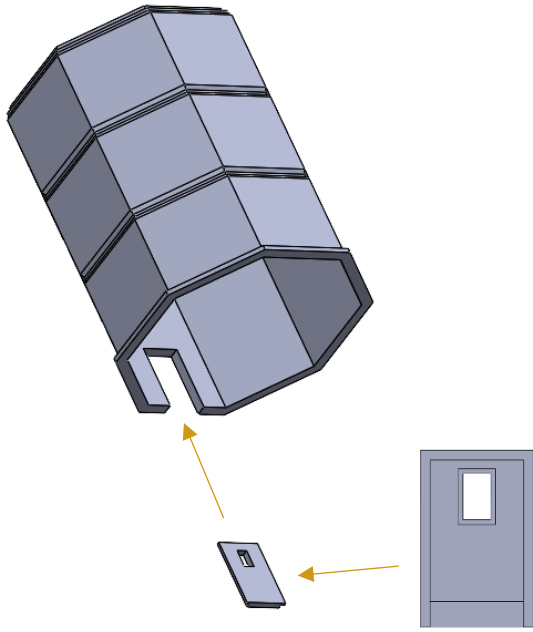

2

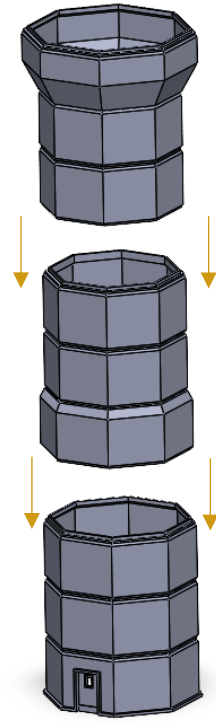

3

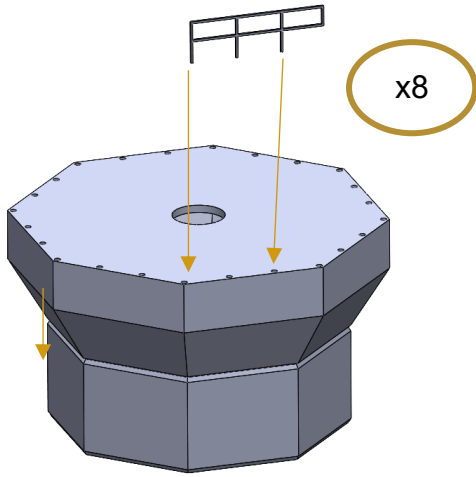

4

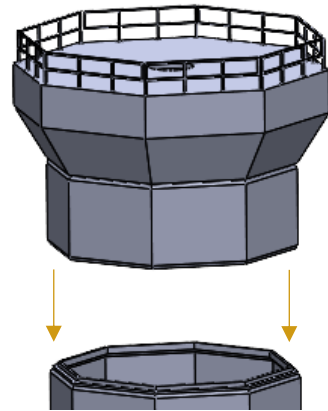

5

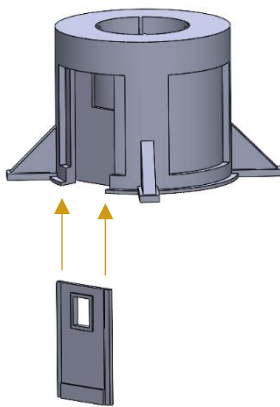

6

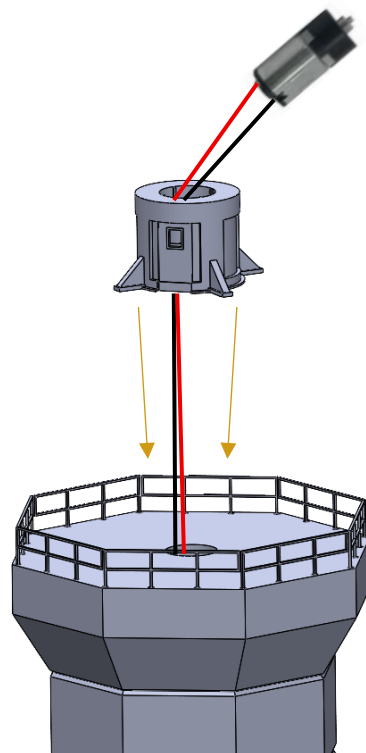

7



Top

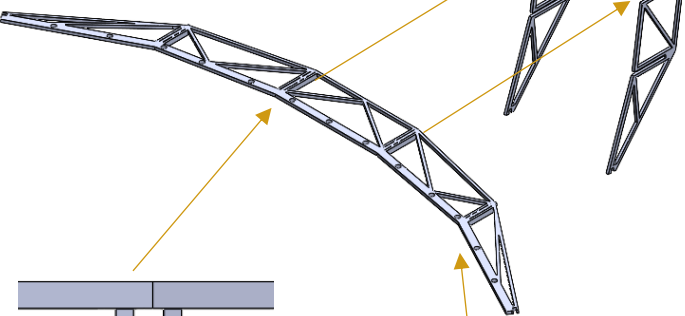

Tabs facing down

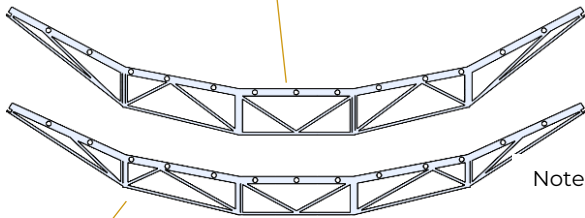

Note different sizes and locations of frame sections

8

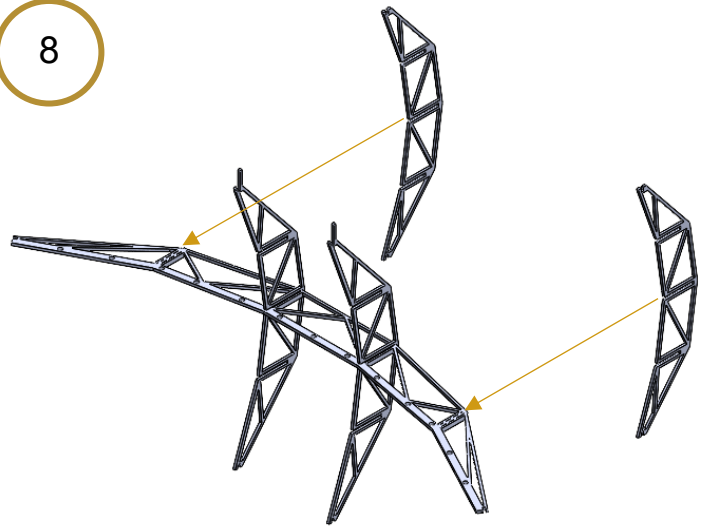

9

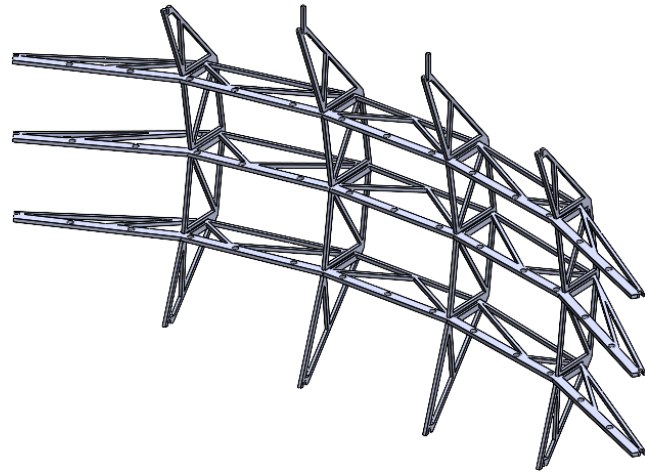
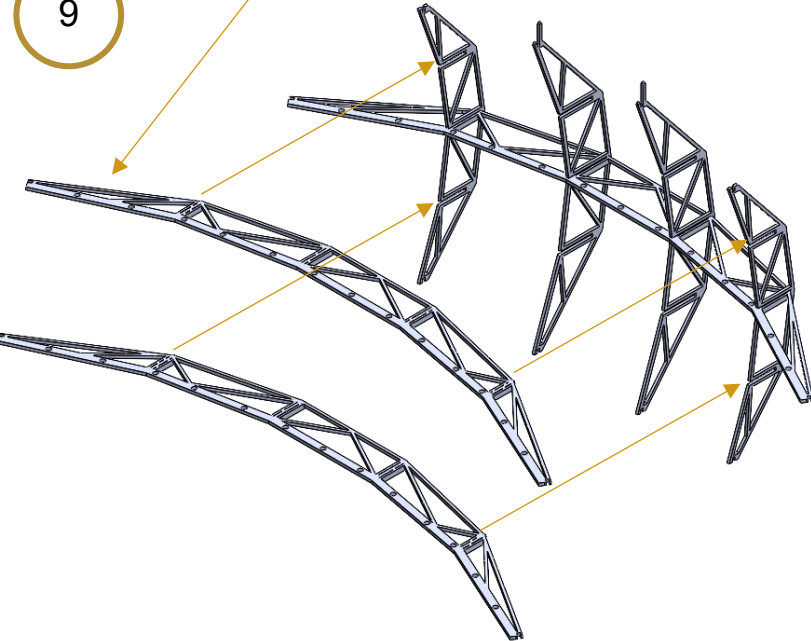

Please Note: Step 10 does not require any glue until 10E

10A

Ensuring you have the frame from Step 9 the right way up, locate the central bar and insert into the top-level holes, working outwards as the bars get shorter

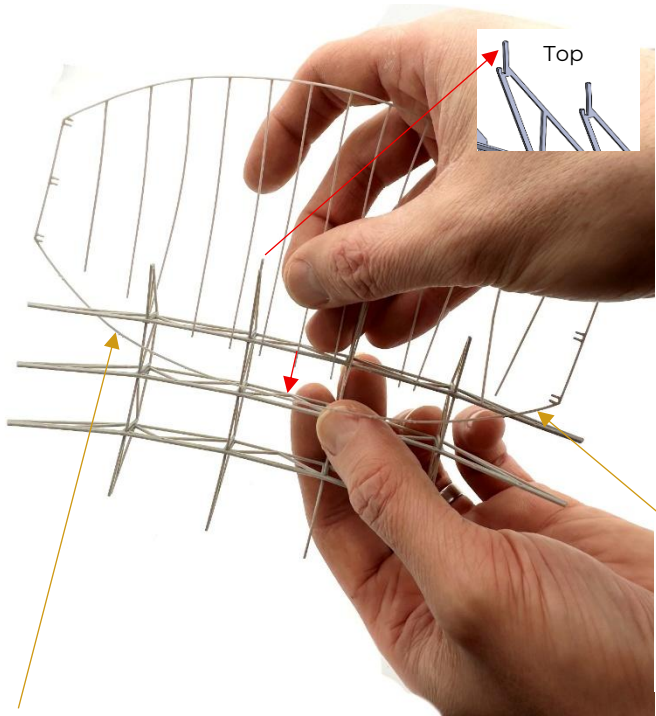

Tabs should be facing up
(away from main structure)

* Tip: Once each bar is through the hole, hold then end of it while moving onto the adjacent bar to prevent it from hopping out the hole and allowing more flex

Ensure outer frame is in front of the main structure

10B

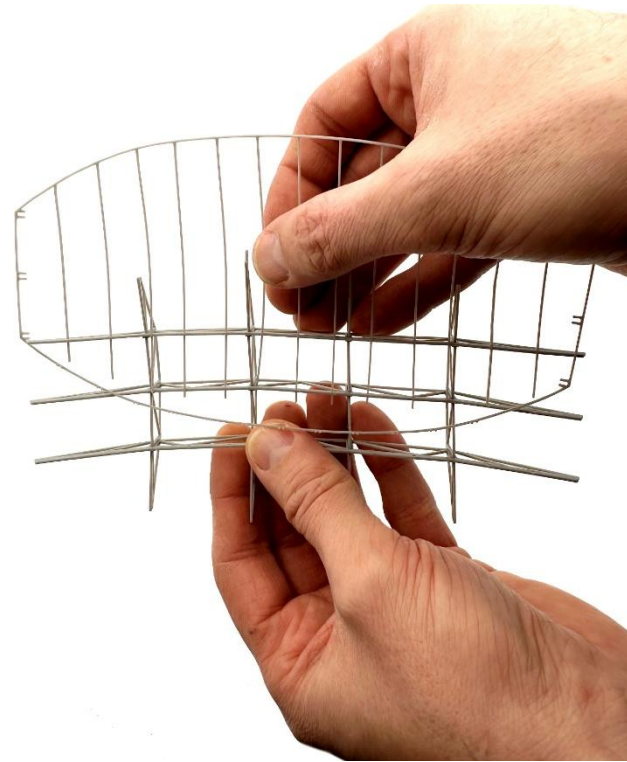

Repeat technique for the 3 levels of holes in the main structure until all bars are through, check all bars at each level before progressing

10C

Once all bars are through, align and insert the 3 end tabs into the slots, repeat for other end

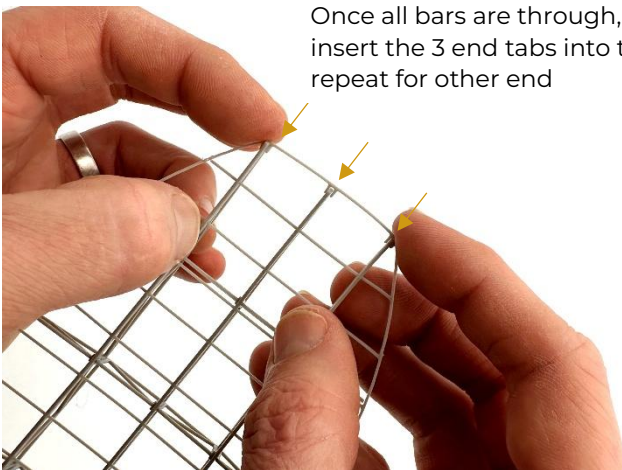

10D

Work your way along the top of the frame, inserting IT into the slots, repeat for bottom of the outer frame.

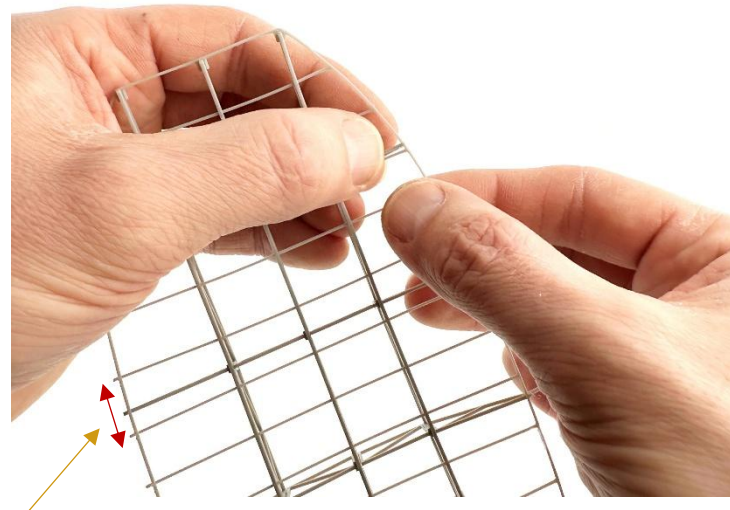

Check and adjust the main frame sections if required, to ensure they are parallel to the rest of the structure

10E

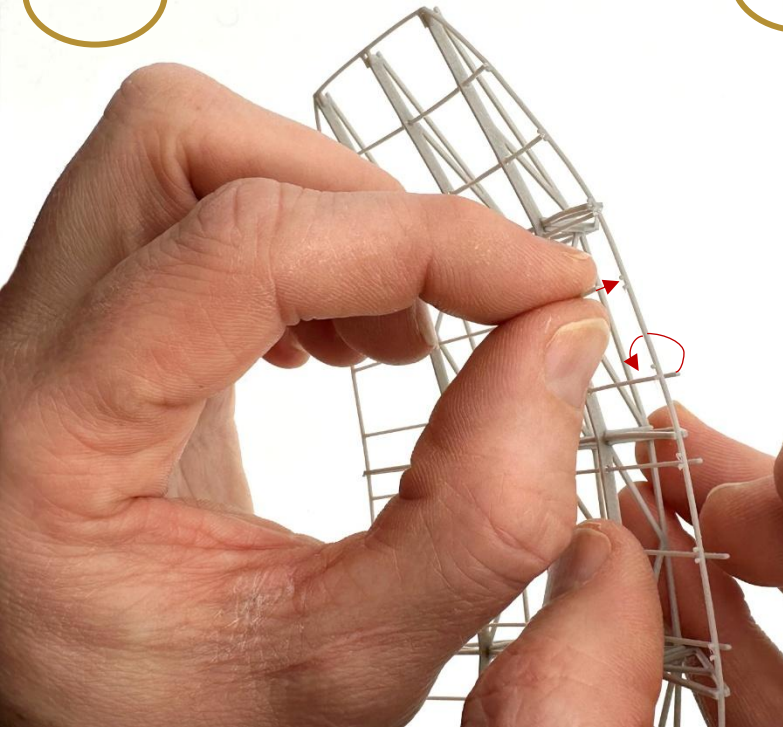

Bend and position each bar to the front of the frame and slot into the tab that aligns with each one, glue can be used to secure these.

10F

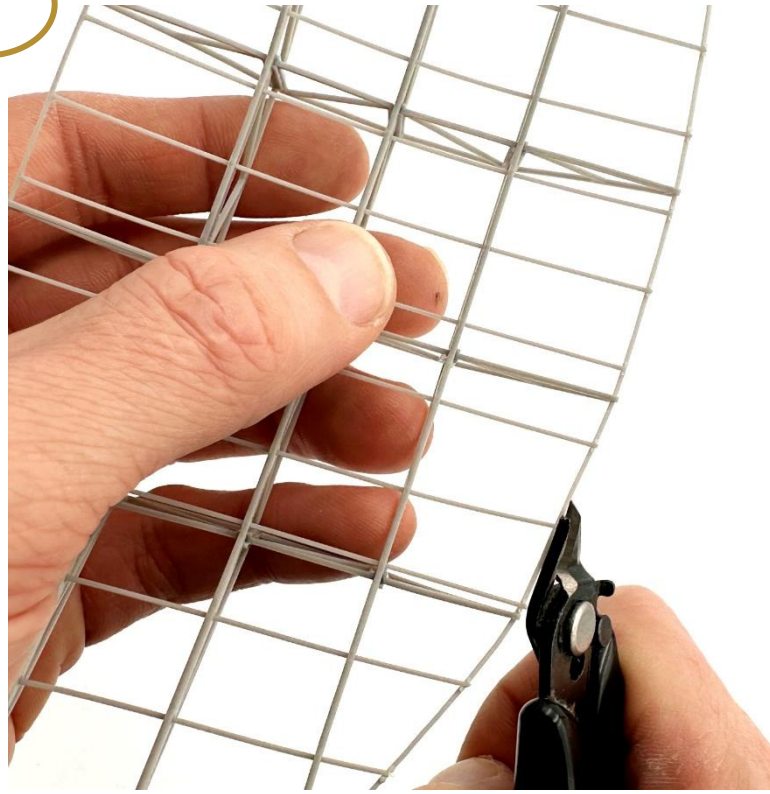

Trim the excess bar length to perfectly align with the outer edge of the main frame.

11

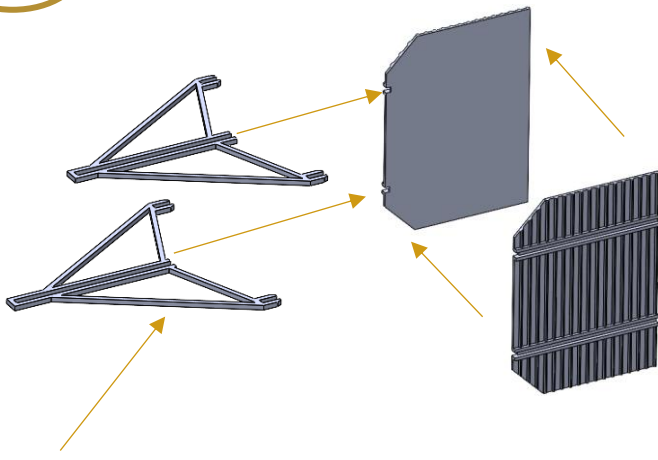

Longer bracket at bottom

12

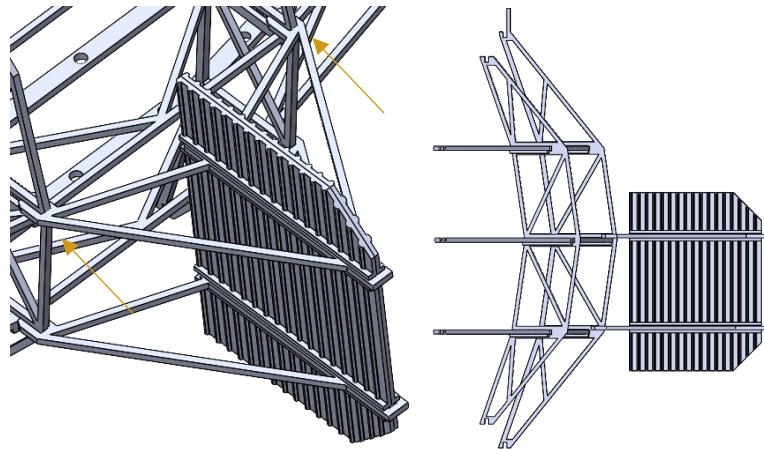

13

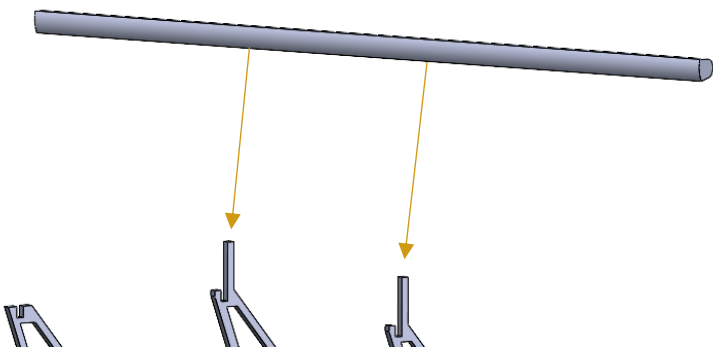

Front

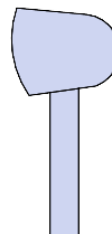

14

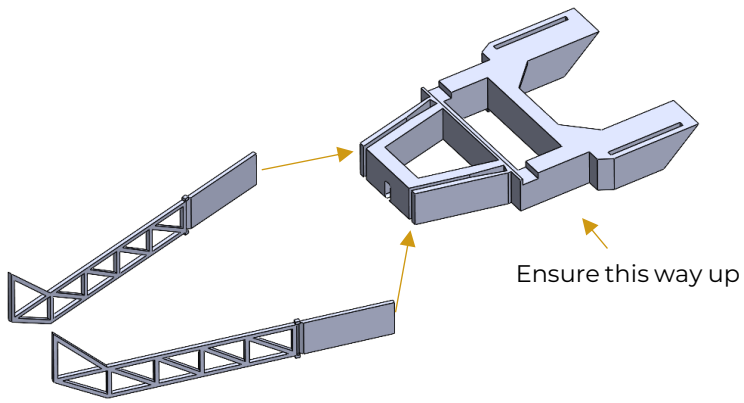

Bend frame sections until parallel

15

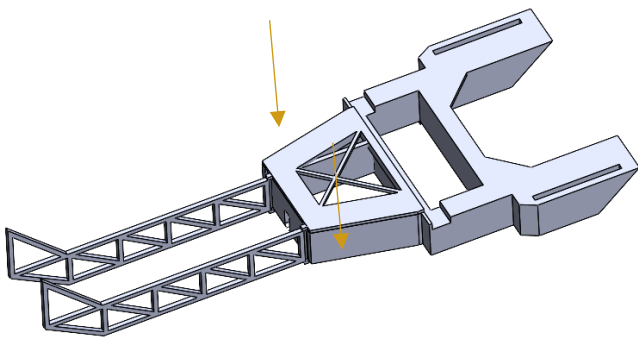

16

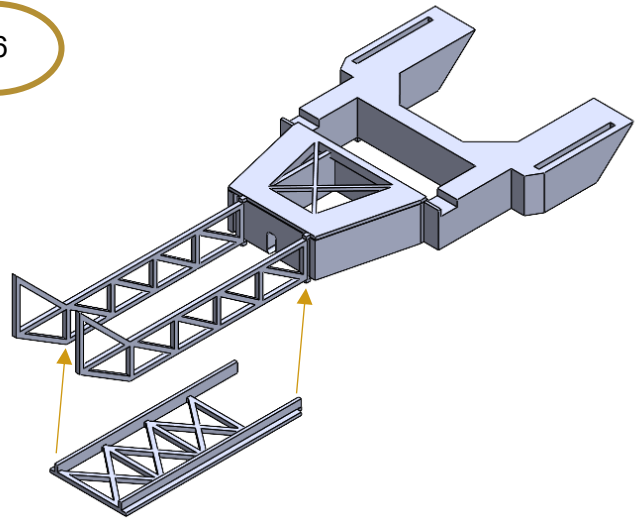

17

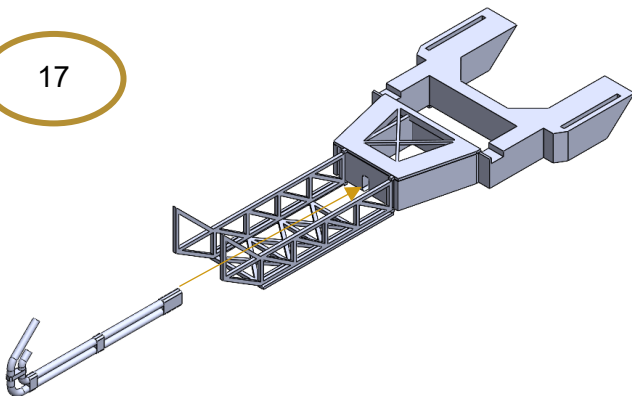

18

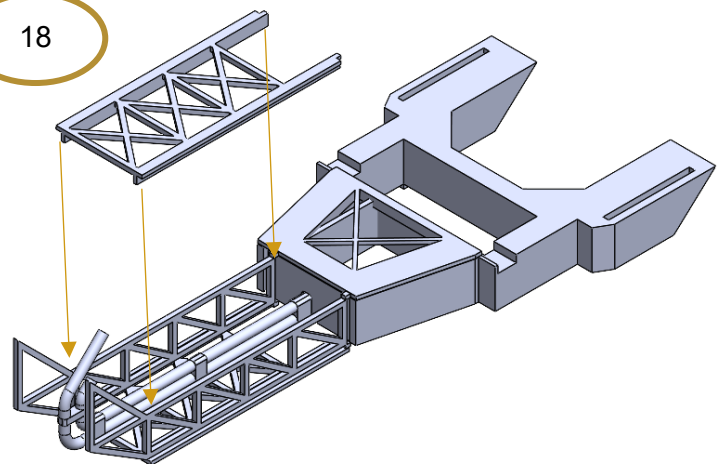

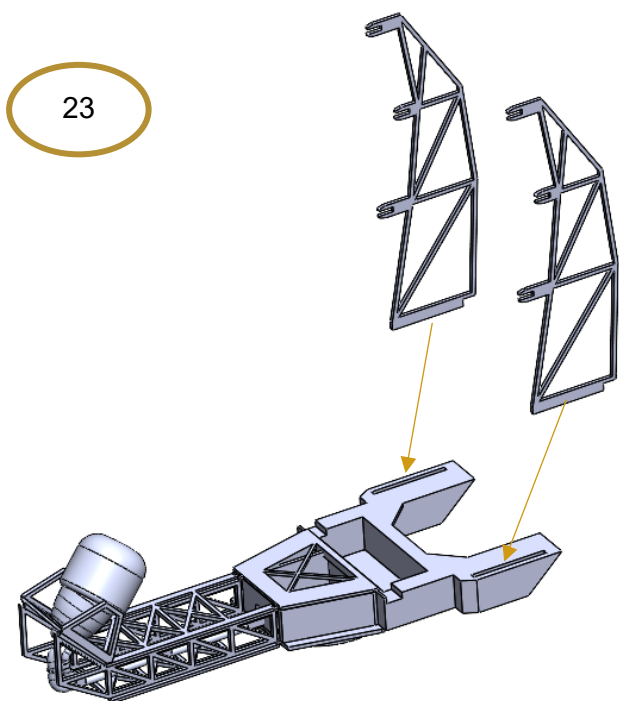
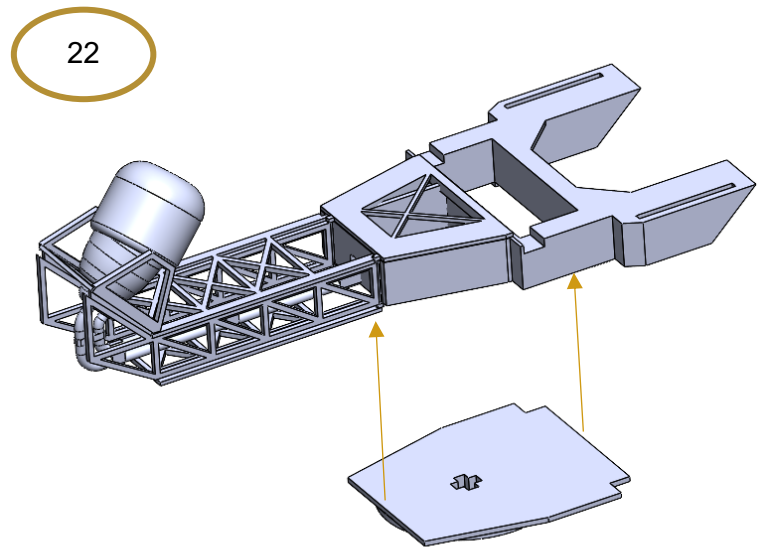
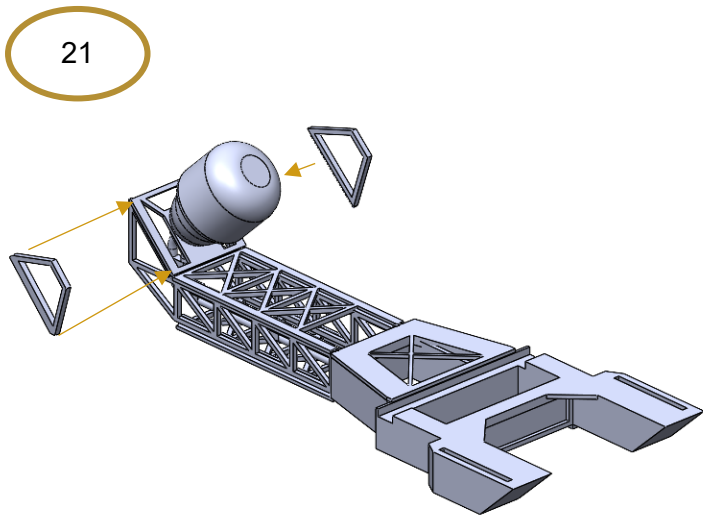
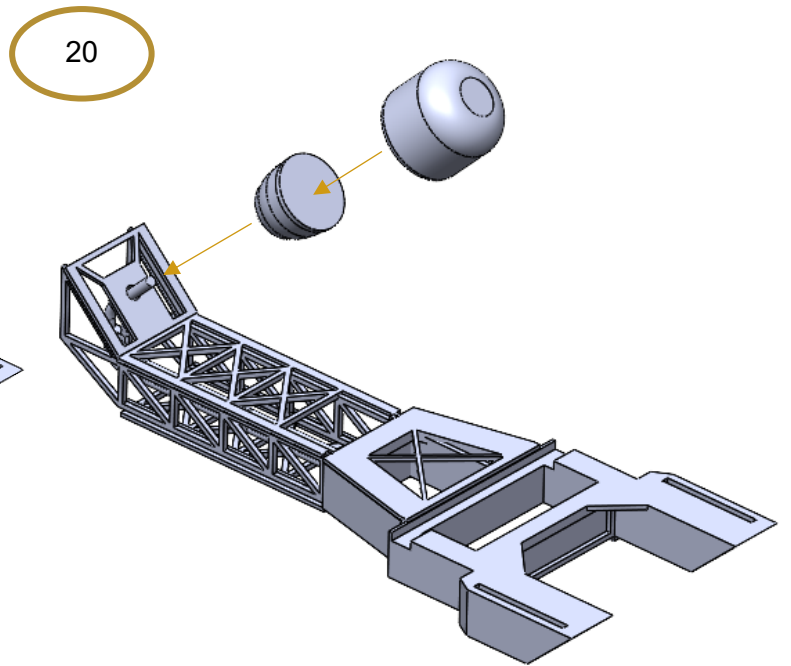
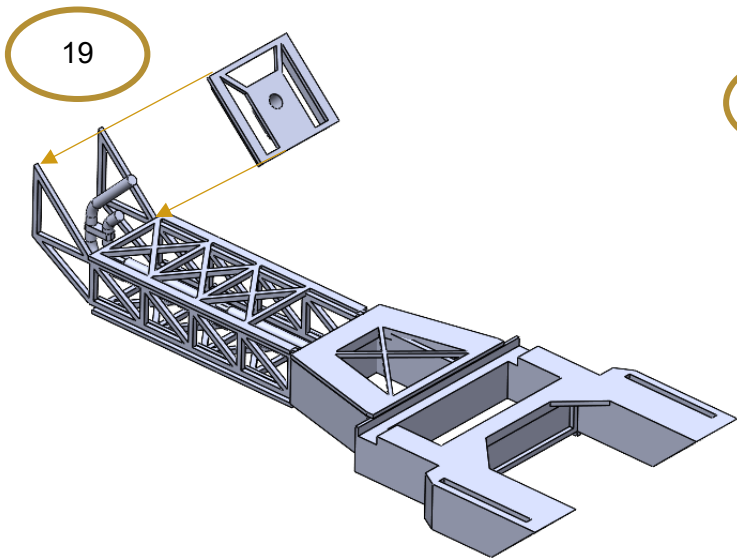



Position the dish centrally into the slot and align with the tabs located on the rear supports until secure, does not have to be glued.

