

DAP251B

Kit Info

Scale	TT
Kit Components	49
Assembly Steps	24

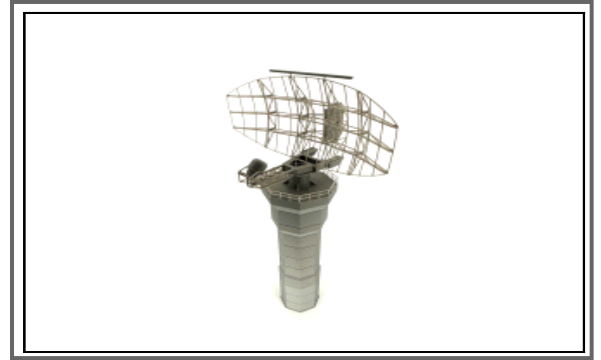

Hints & Tips

Prep

- Carefully unpack all components from the box
- Ensure all parts are present and undamaged
- Remove any small imperfections or edges

Glue

- Use Super Glue for best results, plastic cements will not bond our kits.
- Hold parts together for 10–20 seconds.
- Super Glue with a precision nozzle recommended.
- Use small amounts to avoid visible glue marks.

Prime

- Always prime before painting for the best finish.
- Use grey/black spray primer (automotive or hobby).
- Halfords Grey or Tamiya Fine Surface Primer are well suited.
- Apply light, even coats, spray from 20–30 cm distance. Allow each coat to fully dry before painting.

Paint

- Use acrylic or enamel paints

Acrylic paints:

- Easy to use and quick drying
- Low odour and water clean-up

Enamel paints:

- Strong, durable finish
- Longer drying time allows smoother results
- Requires solvents for thinning/cleaning

Trusted brands:

- Revell (widely available, good all-round range)
- Humbrol (well-known enamel & acrylic range)
- Tamiya (good all-round, airbrush friendly)
- Vallejo (excellent for brush painting)
- Citadel (great for beginners & detail work)

Application tips:

- Apply multiple thin coats
- Avoid thick layers to preserve detail
- Use a fine brush for small details

- This product is **not a toy** and contains small parts.
- Recommended for **ages 12+**, or younger users with **adult supervision**.
- Take care when using **sharp tools** (craft knives, files, & other modelling tools).
- Use adhesives, paints & solvents in a **well-ventilated area**, noting brand guidelines.
- Avoid contact with skin and eyes when using **glues, paints, or chemicals**.
- Keep all materials and tools **out of reach of children**.
- Do not leave models in **direct sunlight, hot cars, or near radiators**.
- **Please note**, some instruction sheets may reflect earlier versions of kits, due to ongoing improvements, parts and assembly steps may vary, if anything does not match or you are unsure, please contact us before proceeding.
- The component count shown on this page includes spare parts, **some small variations in quantity may occur**.

1

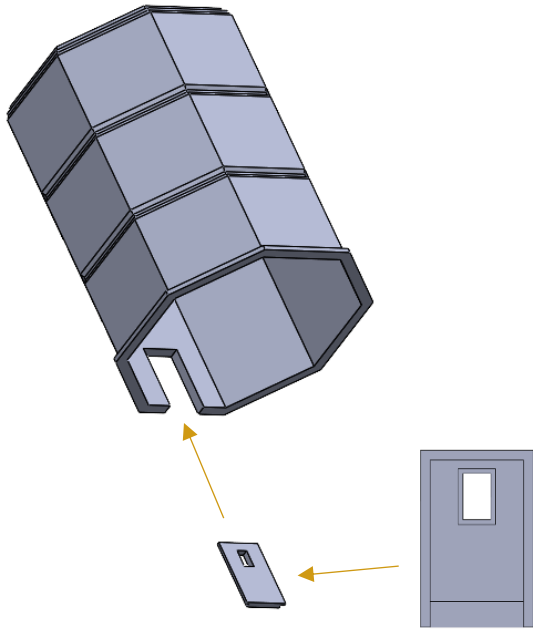

2

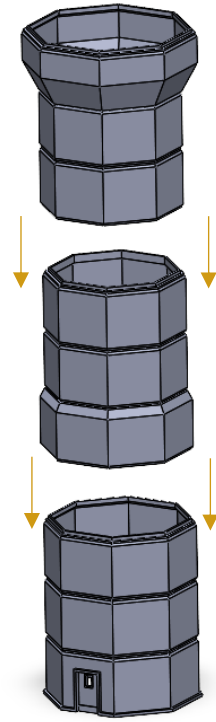

3

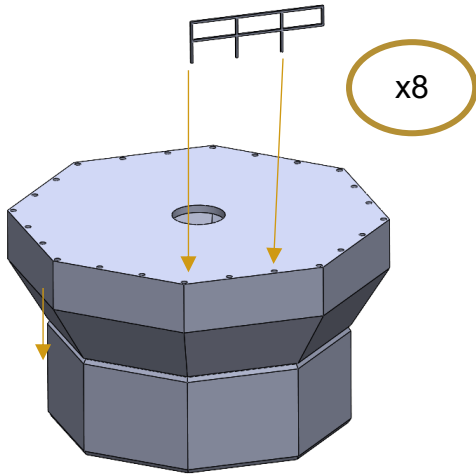

4

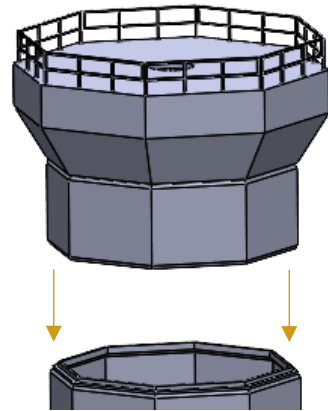

5

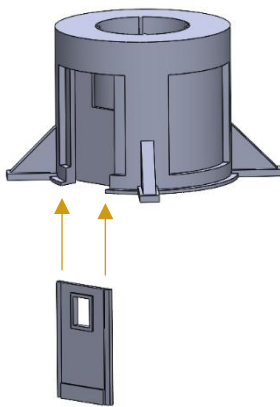

6

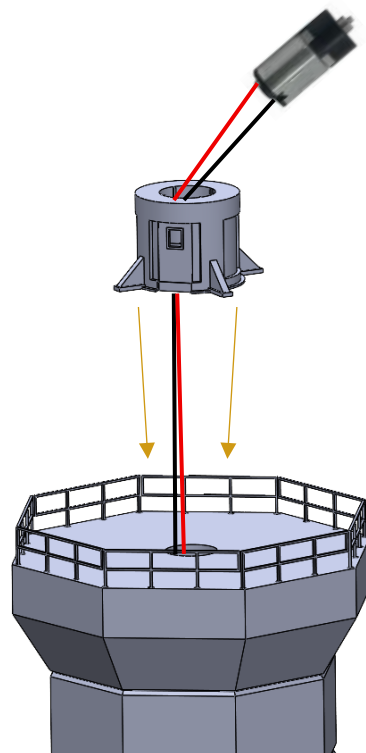

7



Top

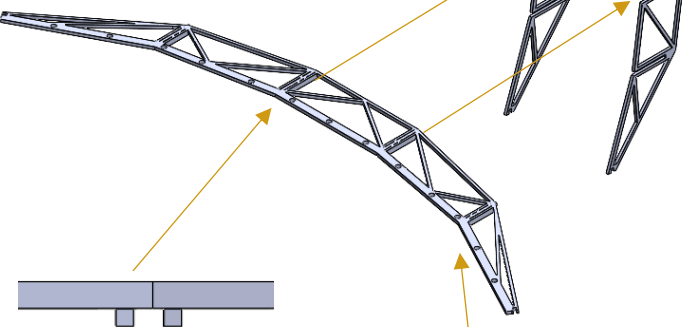

Tabs facing down

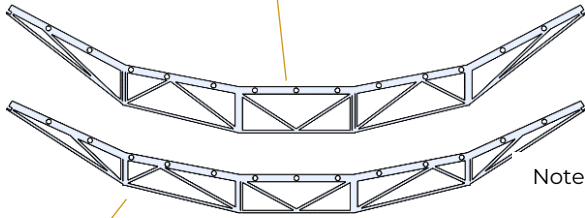

Note different sizes and locations of frame sections

8

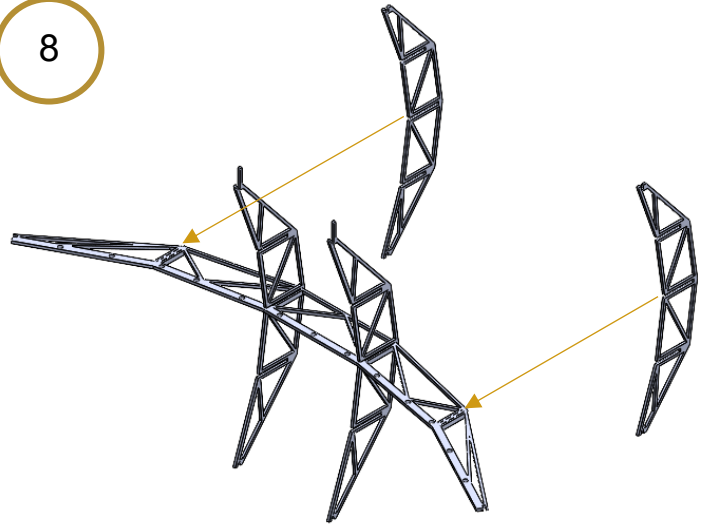

9

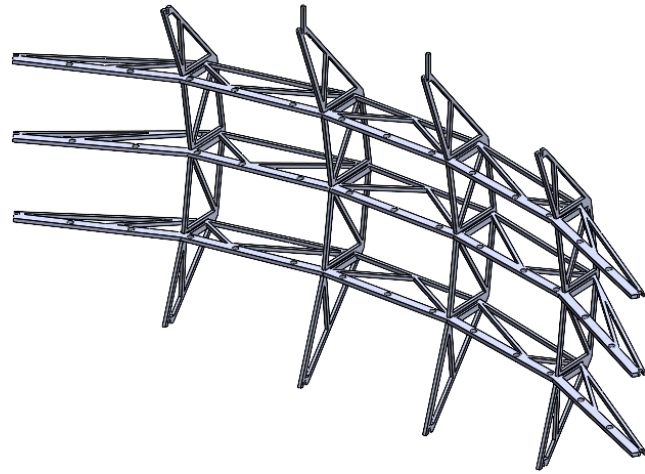
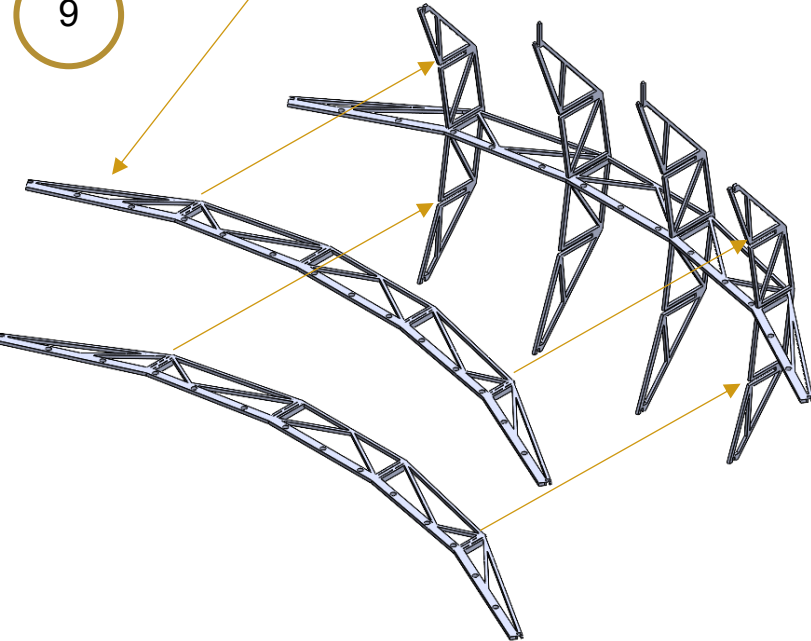

Please Note: Step 10 does not require any glue until 10E

10A

Ensuring you have the frame from Step 9 the right way up, locate the central bar and insert into the top-level holes, working outwards as the bars get shorter

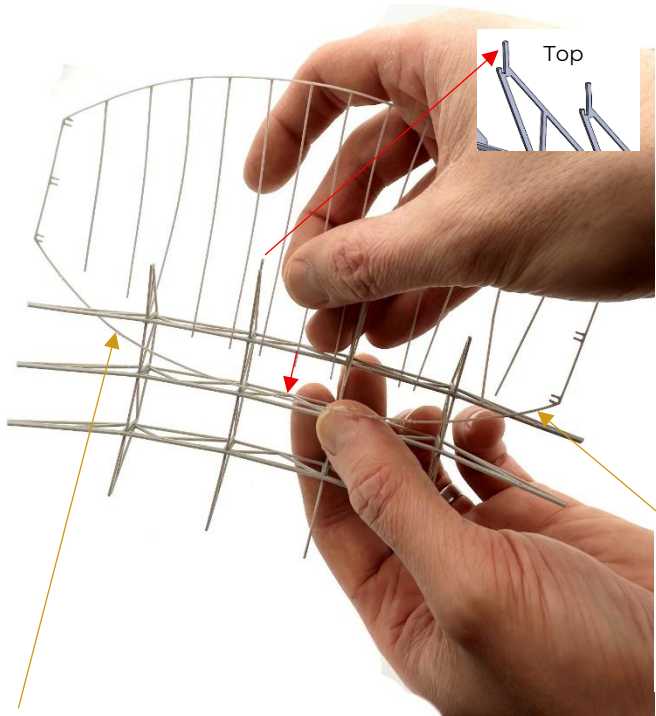

Tabs should be facing up
(away from main structure)

* Tip: Once each bar is through the hole, hold then end of it while moving onto the adjacent bar to prevent it from hopping out the hole and allowing more flex

Ensure outer frame is in front of the main structure

10B

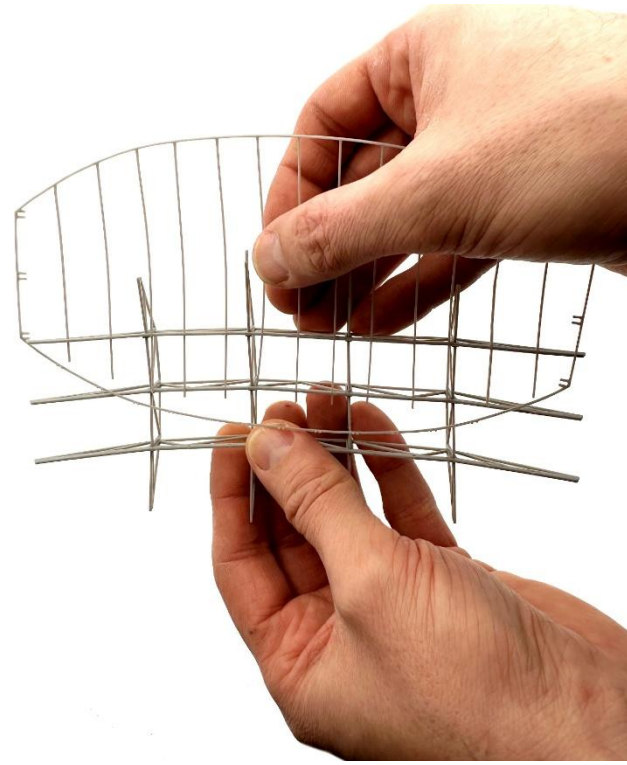

Repeat technique for the 3 levels of holes in the main structure until all bars are through, check all bars at each level before progressing

10C

Once all bars are through, align and insert the 3 end tabs into the slots, repeat for other end

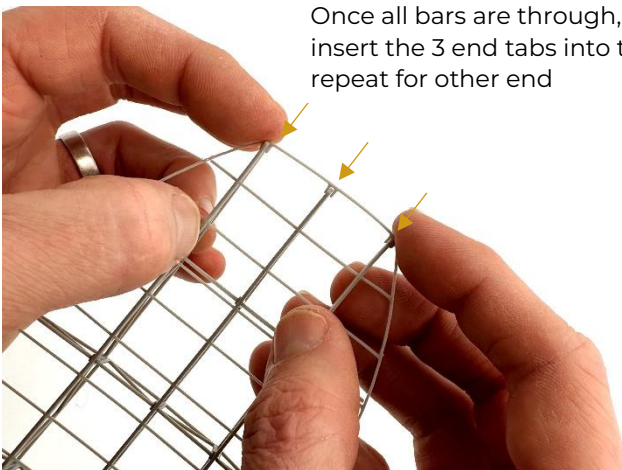

10D

Work your way along the top of the frame, inserting IT into the slots, repeat for bottom of the outer frame.

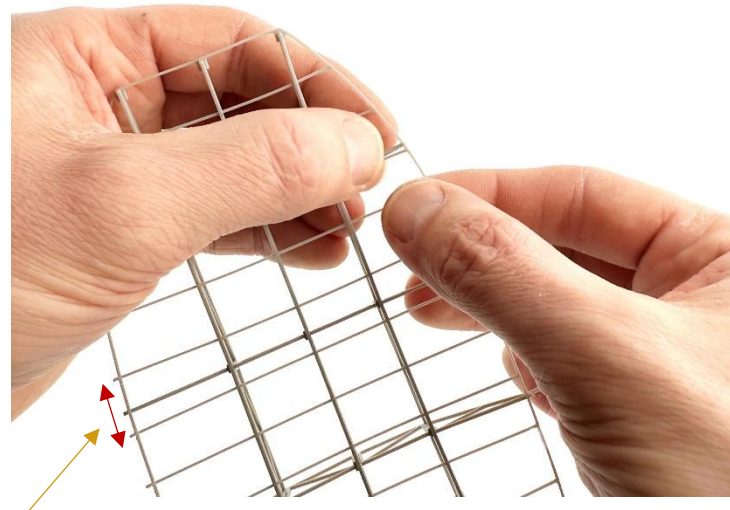

Check and adjust the main frame sections if required, to ensure they are parallel to the rest of the structure

10E

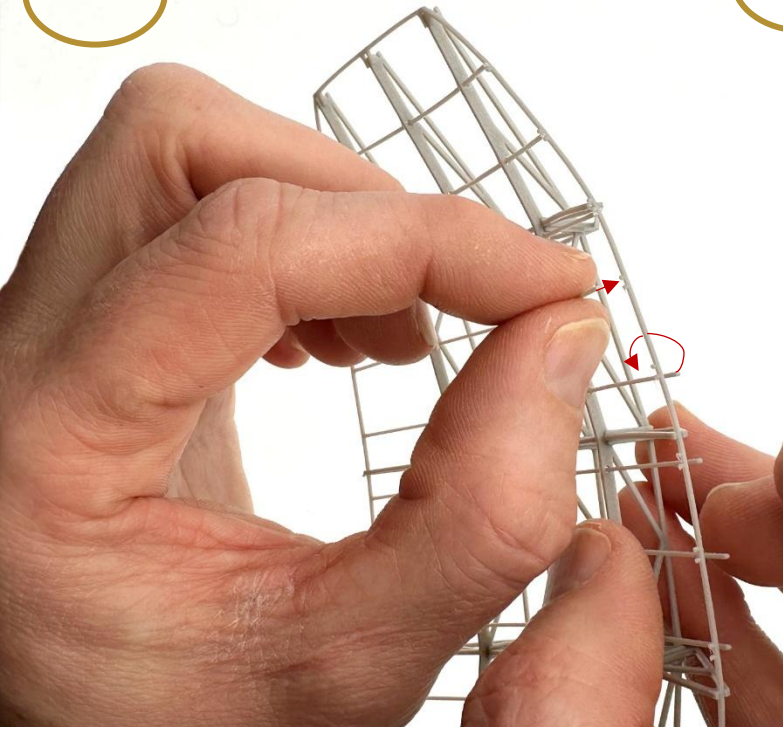

Bend and position each bar to the front of the frame and slot into the tab that aligns with each one, glue can be used to secure these.

10F

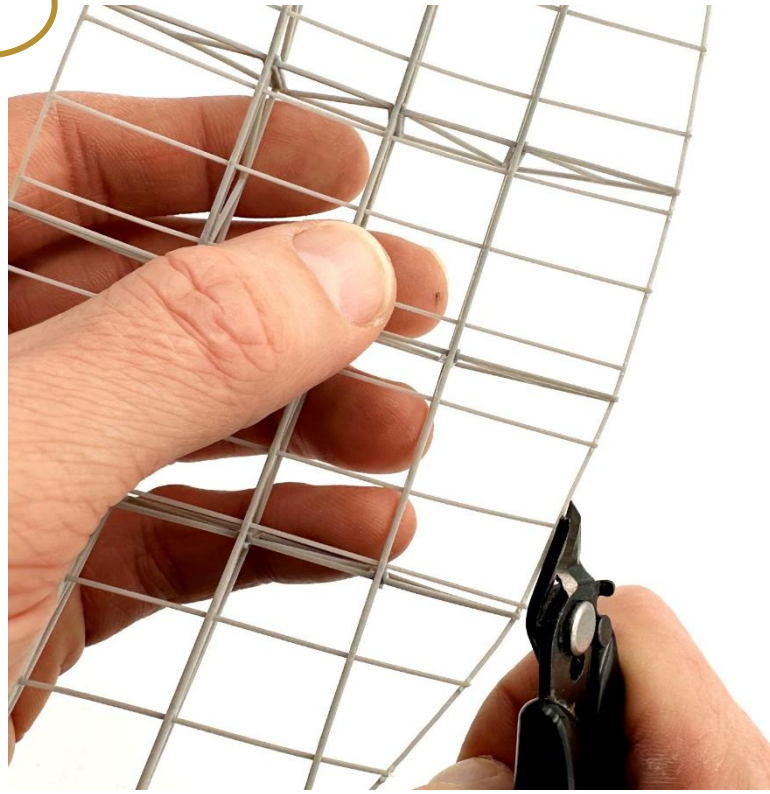

Trim the excess bar length to perfectly align with the outer edge of the main frame.

11

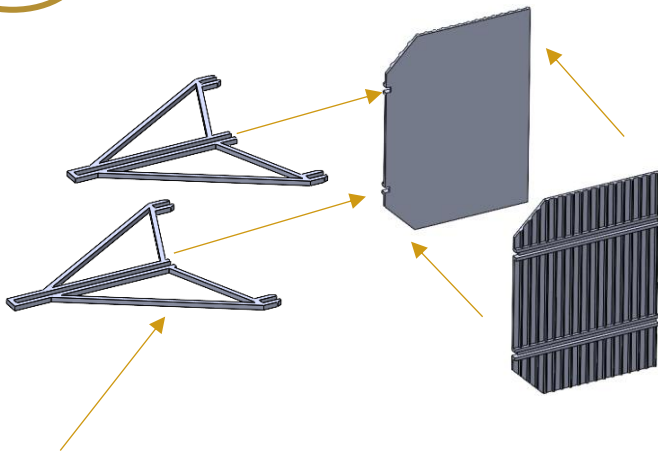

Longer bracket at bottom

12

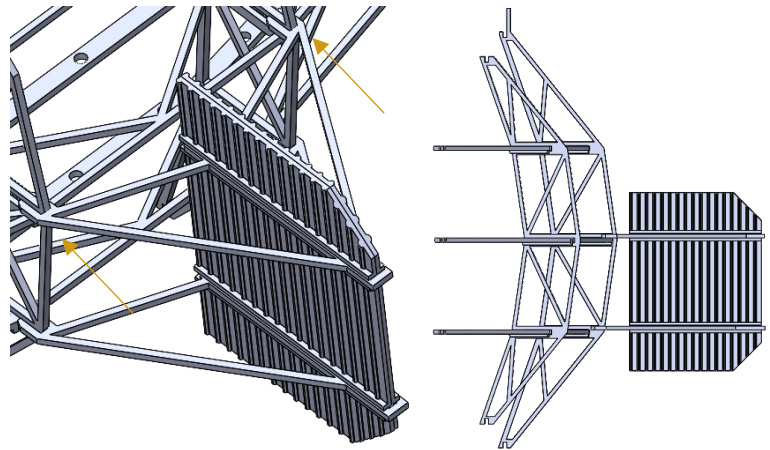

13

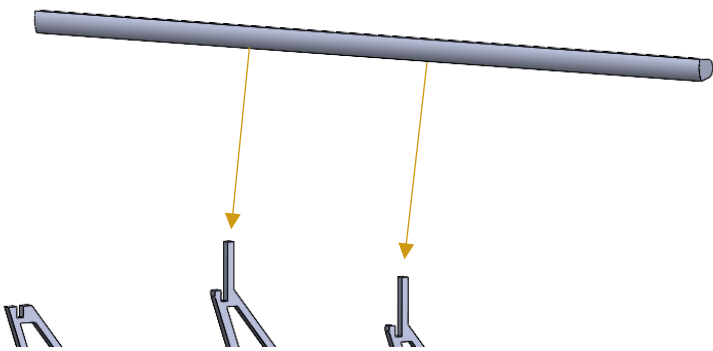

Front

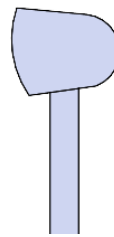

14

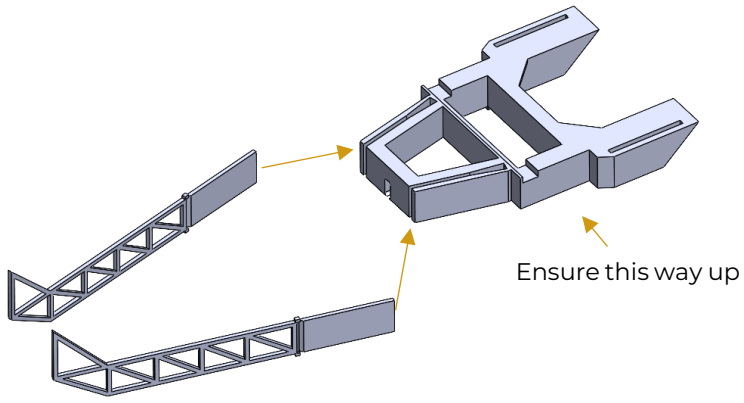

Bend frame sections until parallel

15

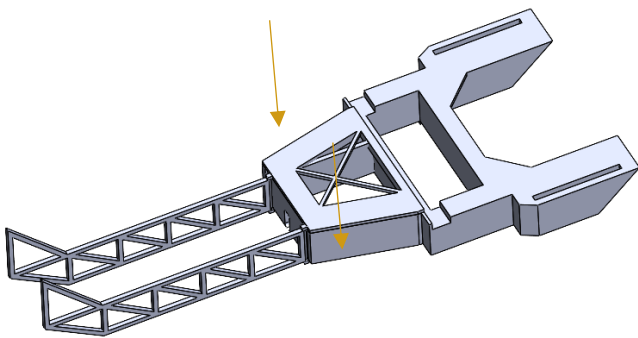

16

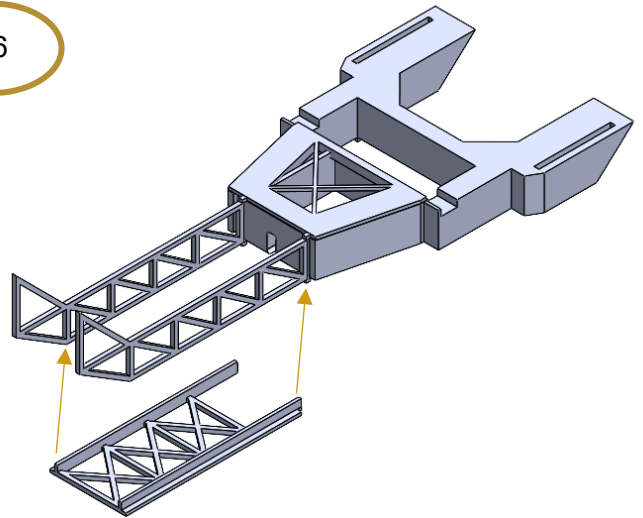

17

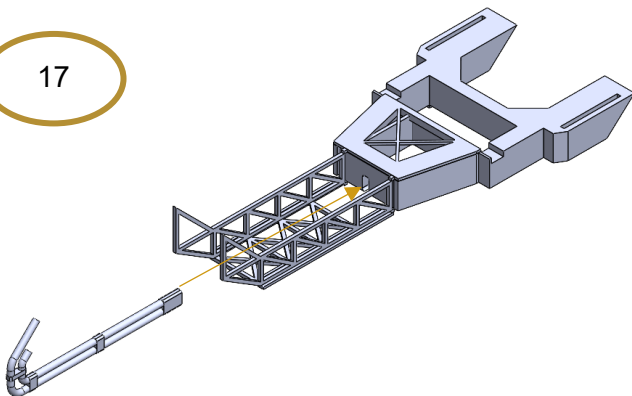

18

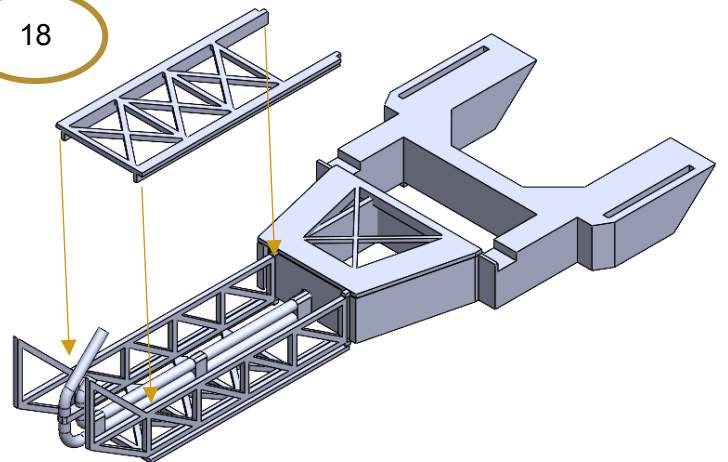

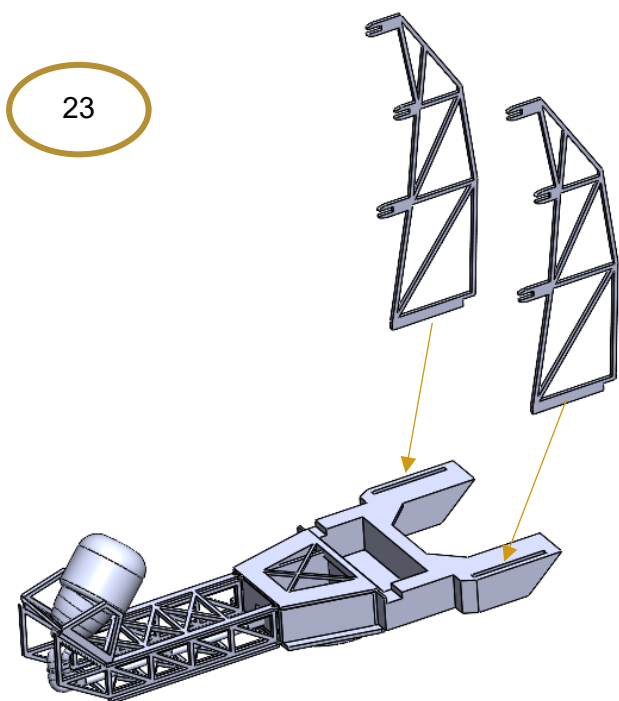
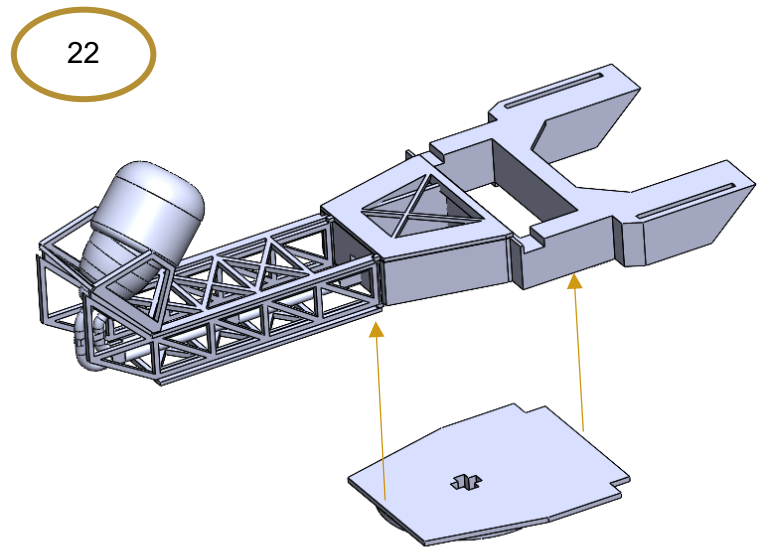
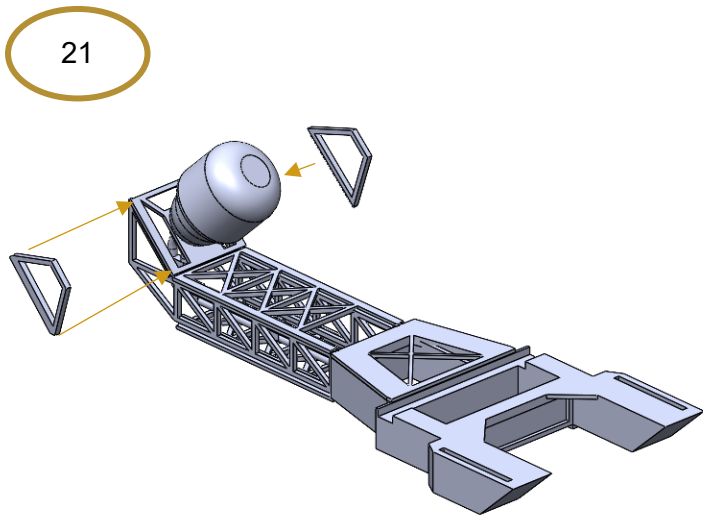
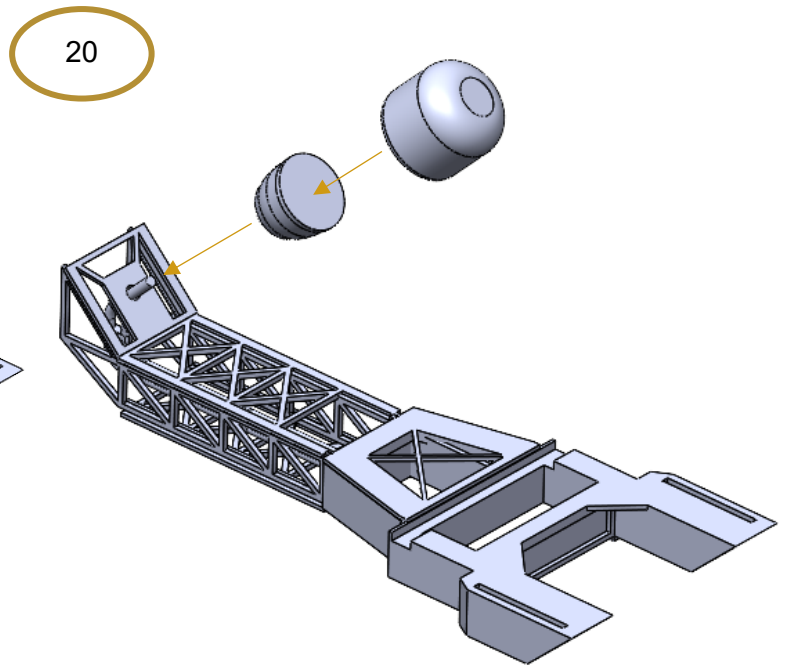
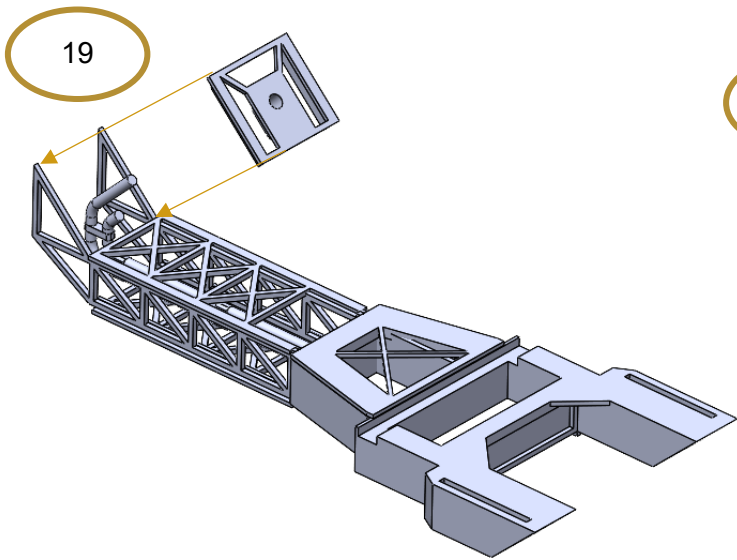

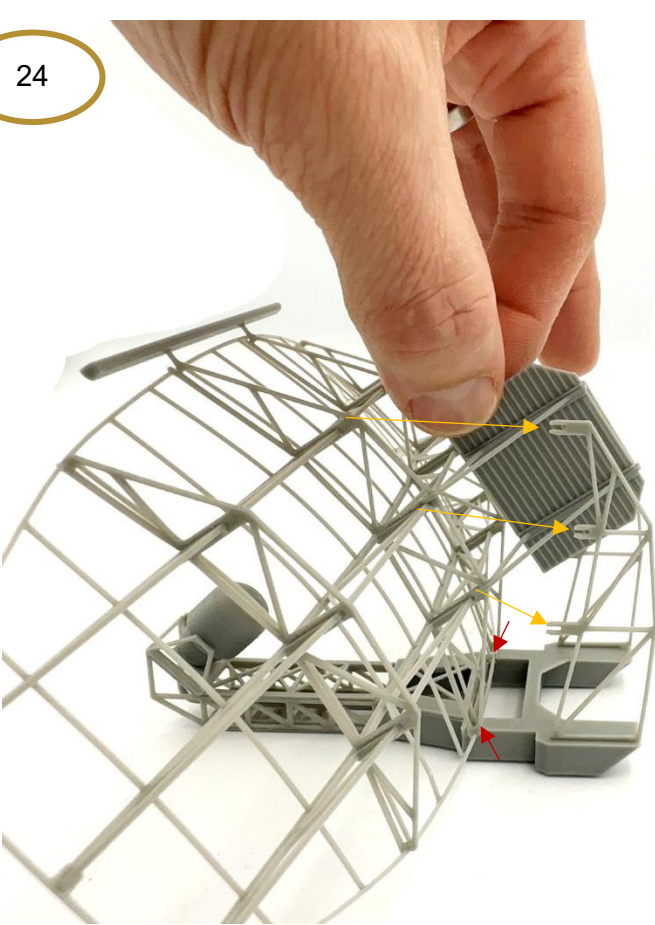

Position the dish centrally into the slot and align with the tabs located on the rear supports until secure, does not have to be glued.

